

BALL VALVES INTEC

K211, DN80 - DN300, PN16/40
trunnion mounted ball, metal seated,
both sides spring loaded seat rings

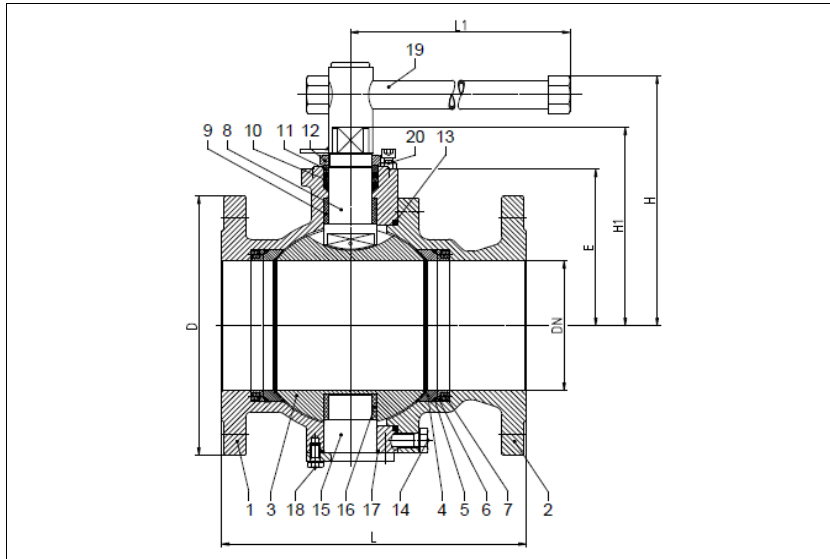

Flanged ball valve
full bore
face to face acc. to EN 558, GR.1
face to face acc. to EN 558, GR.27
flanges acc. to EN 1092

Specification:

Two-piece ball valve with flanges acc. to EN 1092, face to face dimensions acc. to EN 558, GR.1/GR.27, full bore, blow-out-proof stem, body material stainless steel (1.4408) or carbon steel (1.0619), antistatic device, free of non ferrous metals, trunnion mounted ball, seat 1.4571/1.4404 hard facing metal coated, stem packing cone ring system acc. temperature use, dynamic loaded adjustable, top flange DIN EN ISO 5211, approved by PED, certified acc. to GERMAN clean air act VDI 2440, Fire-Safe acc. to DIN EN ISO 10497, with lever.

Marking: INTEC K211

No.	Part	Material	Material
High temperature design			
1	body	1.0619	1.4408
2	cap	1.0619	1.4408
3	ball	1.4408 hard facing metal coated	
4	seat	1.4571/1.4404 hard facing metal coated	
5	bearing ring seal	Graphite	
6	thrust collar	1.4571/1.4404	
7	spiral spring	Inconel X750	
8	stem	250°C 1.4462	350°C 1.4313
		400°C 1.4980	250°C 1.4462
		350°C 1.4980	400°C 1.4980
9	stem bearing	E-carbon	
10	stem seal	1.4571/1.4404/Graphite	
11	bearing	E-carbon	
12	hex. nut self-locking	A2/1.4301	
13	body seal	Graphite	
14	hex. screw	A4-70	
15	bearing neck (< DN125 with screwed end)	1.4571/1.4404	
16	bearing	E-carbon	
17	trunnion seal	Graphite	
18	hex. screw (as from DN150)	A4-70	
19	lever	1.4408/1.4308/steel zincplated	
20	stopper	A2	
Fire-Safe design			
9	below stem seal	KFGN/Graphite	
	bearing	1.4401/KF	
10	upper stem seal	KFAM/Graphite	
	Fire-Safe seal	Graphite	
11	ring	1.4571/1.4404	
	thrust washer	PEEK	
13	combined body seal	KF-Graphite	
16	bearing	1.4401/KF	
Standard design			
5	bearing ring seal	KF	
7	spiral spring	1.4401	
9	below stem seal	KFGN/Graphite	
	bearing	1.4401/KF	
10	upper stem seal	KFAM/Graphite	
11	bearing	PEEK	
13	body seal	KF	
16	bearing	1.4401/KF	
17	trunnion seal	KF	

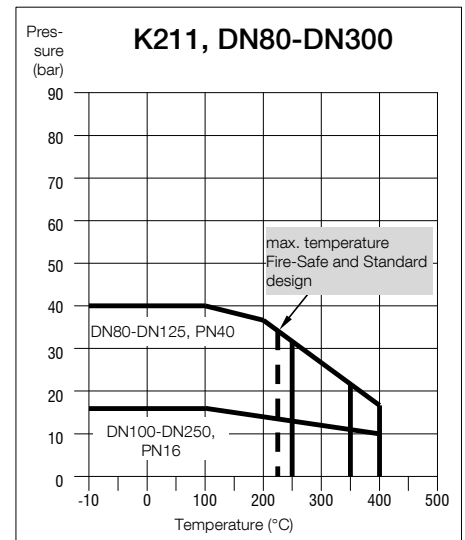

Ordering example:
INTEC K211, DN125, PN40, GR.27,
1.4404, Fire-Safe, 1.4980 (stem)

- * Necessary torque measured with treated water at Δ P acc. to pressure class and room temperature.
- ** Gearbox recommended
- *** free stem, gearbox/automation necessary

Dimensions

DN mm	PN	dimensions (mm)			L GR. 1	L GR. 27	D	E	H1	top flange ISO	torque Nm *	ca. weight kg	
		H	L1									GR. 1	GR. 27
80	40	194.0	500		310	180	200	112.5	155.0	F10	355**	26	24
100	16	221.5	500		350	190	220	137.0	179.5	F12	265	34	32
100	40	221.5	500		350	190	235	137.0	179.5	F12	510**	35	34
125	16	246.5	700		-	325	250	164.0	206.5	F12	350	-	57
125	40	246.5	700		-	325	270	164.0	206.5	F12	725**	-	60
150	16	263.0	700		-	350	285	181.0	229.5	F12	485**	-	80
200	16	304.0	1000		-	400	340	225.0	284.5	F14	935**	-	140
250	16	340.5	1200		-	450	405	261.5	321.0	F14	1525**	-	250
300	16	- ***	- ***		-	500	460	311.0	400.0	F16	o.R.**	-	320

Other flange connections and materials on request.